



# ELECTRO-FLEX HEAT

a Division of ThreeHeat, LLC

## Product Data Sheet for Enclosure Heaters

### FEATURES

- Standard sizes in the most frequently requested dimensions for immediate delivery
- 115V standard, 230V available
- Operating temperature range of -40°F to 350°F
- Available with built-in thermostat in two configurations
- Resistant to many chemical substances
- Choice of attachment to aluminum mounting plate
- Pre-drilled standard mounting plate
- Horizontal or vertical mounting
- UL Recognized and CSA Certified
- Custom products available

### APPLICATIONS

Provides freeze prevention and condensation build-up protection in enclosures where heat is needed:

- Circuitry boxes
- Instrument cabinets
- Service panels
- Signal boxes
- ATM machines

Please contact the engineering department at Electro-Flex Heat, a Division of ThreeHeat, LLC, for assistance with specific applications.



### GENERAL INFORMATION

Enclosure Heaters are made of etched foil heating circuits laminated between thin layers of fiberglass-reinforced, high temperature insulation, silicone rubber, and may be attached to an aluminum mounting plate by factory vulcanization or with PSA (Pressure Sensitive Adhesive).

Enclosure Heaters may be used on various enclosures in which effective temperature control is desirable. They offer safe and effective protection against problems brought on by temperature variations such as condensation. Certain temperature conditions may cause a moisture buildup which can be very damaging to electric equipment, affecting proper function and leading to equipment failure. Condensation buildup and freezing can affect poorly insulated enclosures as well as those that are well-sealed and protected. Using enclosure heaters is a cost-effective way to avoid replacing and repairing equipment damaged by inefficiently controlled temperatures.

A built-in, air sensing thermostat maintains the temperature to prevent freezing or condensation within the enclosure. Two thermostat configurations are available: direct mounted, where the thermostat is molded into the heater; and remote mounted, where a remote thermostat attaches to one of the leads so the customer can place it in any location in the application.

The mounting plates are drilled with 0.25in. holes for mounting to sub panels and other surfaces. Enclosure Heaters can be mounted vertically or horizontally using this mounting plate. Optimal temperature control is achieved by vertically mounting an Enclosure Heater with a direct thermostat.

### How to order:

1. Specify model number (see Figure 2).
2. Contact factory or representative (see back page for contact information)

# Enclosure Heaters



**Table 1. General Specifications**

Characteristic	Value
Material and construction	fully vulcanized fiberglass-reinforced silicone rubber encapsulating a nickel alloy or a thin foil heating element
Voltage	115V
Power densities available (115 V)	5 W/in. <sup>2</sup>
Operating temperature range: with thermostat without thermostat	-40°F to 350°F see Figure 2 for available set points
Exposure temperature range: with thermostat without thermostat	-40°F to 350°F see Figure 2 for available set points
Resistance tolerance	±10%
Thickness	0.125in.
Leads: gage insulation length	22 AWG Teflon® 48.0in. min.
Component approvals	UL, CSA
High-potential dielectric testing (115 V)	1250V
Serviceable parts	none

**Note:** \*See Figure 2 for available lengths.

**Table 2. Desired Temperature vs Total Enclosure Surface Area (W)\***

Desired Temp. (F°)	Total Enclosure Surface Area (ft <sup>2</sup> )												
	2	3	4	5	6	7.5	10	15	20	25	30	40	50
20	30	40	55	70	80	100	135	205	270	335	405	540	670
	10	10	15	20	20	25	35	50	65	80	100	130	160
40	80	80	110	135	160	200	270	405	540	670	805	1075	1340
	15	20	30	35	40	50	65	100	130	160	195	250	320
60	90	120	160	205	245	300	405	605	805	1005	1210	1610	2010
	20	30	55	50	60	75	100	145	195	240	290	385	480
80	110	160	215	270	325	400	540	805	1075	1340	1610	2145	2680
	30	40	55	65	80	100	130	195	250	320	395	515	640
100	135	200	270	335	405	500	670	1005	1340	1675	2010	2680	3350
	35	50	65	80	100	125	160	240	320	400	480	540	800
120	165	240	320	405	485	600	805	1210	1610	2010	2415	3220	4020
	40	60	80	100	115	150	195	290	325	460	500	770	960
140	190	280	375	470	565	700	940	1410	1880	2345	2815	3755	4690
	45	70	80	115	135	175	225	340	450	500	675	800	1120

**Note:** \*Non-shaded areas indicate enclosure with no insulation; shaded areas indicate enclosure with 1in. fiberglass insulation.

**How to use Table 2:**

1. Determine the total enclosure surface area (four sides plus top and bottom).
2. Find total enclosure surface area on the horizontal axis.
3. Find desired temperature on the vertical axis.
4. The intersection of these two axes indicates the wattage needed to maintain the desired temperature.

Figure 1. Mounting Plate Dimensions (For reference only. in.)

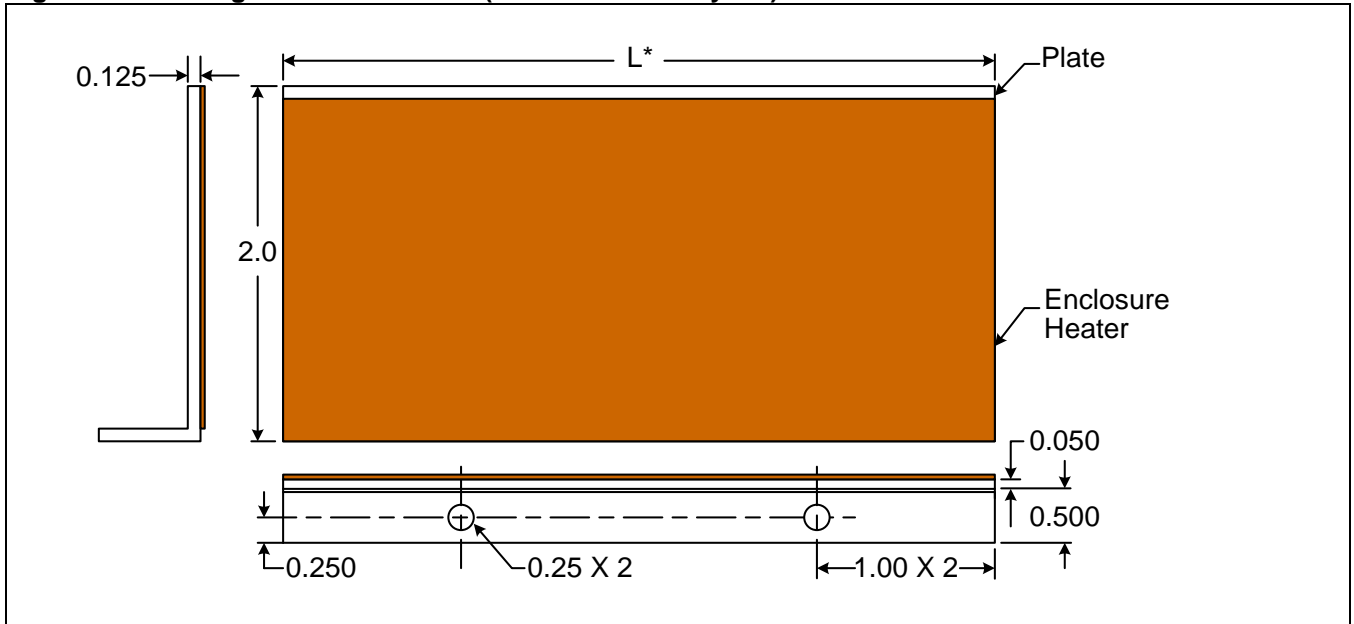
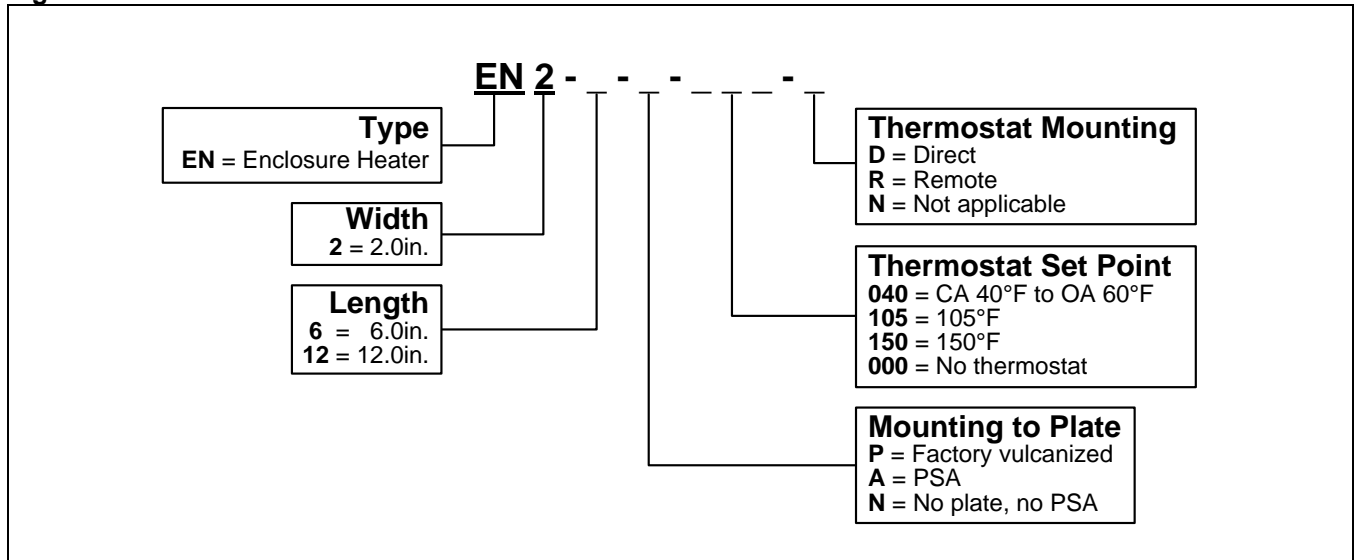

Figure 2. Model Number Order Guide





## WARRANTY AND LIMITATION OF REMEDY AND LIABILITY

**Electro-Flex Heat, a Division of ThreeHeat, LCC (hereafter referred to as “Electro-Flex Heat”)** warrants its products against defects in material and workmanship for at least one (1) year from the time of delivery, provided such product is properly applied, used and maintained. **Electro-Flex Heat** does not warrant any product against damage from corrosion, contamination, misapplication, improper specification or wear and tear and operational conditions beyond **Electro-Flex Heat’s** control. The terms of this warranty are the exclusive terms available to buyer and to any other person or entity to which products are transferred during the period of this warranty. No person has authority to bind **Electro-Flex Heat** to a presentation or warranty other than this express warranty.

**Electro-Flex Heat** shall not be liable for incidental or consequential damages resulting from use of the products whether a claim for such damage is based upon warranty, contract, negligence or other cause of action. Should any product fail while subject to this warranty, such product shall be repaired or replaced, at **Electro-Flex Heat’s** option, at no charge to buyer or to any other person or entity to which product is transferred during the period of this warranty. **Electro-Flex Heat** must be notified of the alleged failure of the product within thirty (30) days of such event and advanced authorization for repair or replacement must be obtained in writing from **Electro-Flex Heat**.

**THIS WARRANTY IS MADE EXPRESSLY IN LIEU OF ALL OTHER WARRANTIES, EXPRESS OR IMPLIED, INCLUDING WITHOUT LIMITATION, ANY WARRANTY ARISING FROM A COURSE OF DEALING OR USAGE OF TRADE, AND ALL OTHER SUCH WARRANTIES ARE SPECIFICALLY EXCLUDED. THE CORRECTION OF ANY DEFECT IN OR FAILURE OF PRODUCTS BY REPAIR OR REPLACEMENT TO THE EXTENT SET FORTH ABOVE, SHALL BE Electro-Flex Heat’s LIMIT OF LIABILITY AND THE EXCLUSIVE REMEDY FOR ANY AND ALL LOSSES, DELAYS OR DAMAGES RESULTING FROM THE PURCHASE OR USE OF THE PRODUCTS. IN NO EVENT SHALL Electro-Flex Heat BE LIABLE FOR SPECIAL, INDIRECT, INCIDENTAL OR CONSEQUENTIAL DAMAGES. Electro-Flex Heat SHALL NOT BE LIABLE FOR, BUYER AND ANY OTHER PERSON OR ENTITY TO WHOM PRODUCTS ARE TRANSFERRED DURING THE PERIOD OF THIS WARRANTY ASSUMES RESPONSIBILITY FOR, ALL PERSONAL INJURY AND PROPERTY DAMAGE RESULTING FROM OR RELATED TO THE HANDLING, POSSESSION OR USE OF PRODUCTS AND PRODUCTS MANUFACTURED AND SOLD BY Electro-Flex Heat HEREUNDER.**

**Electro-Flex Heat IS NOT LIABLE FOR LABOR COST INCURRED IN REMOVAL, REINSTALLATION, OR AUTHORIZED REPAIR OF THE PRODUCT OR FOR DAMAGE OF ANY TYPE WHATSOEVER, INCLUDING INCIDENTAL OR CONSEQUENTIAL DAMAGE.**

**USERS ARE RESPONSIBLE FOR THE SUITABILITY OF THE PRODUCTS TO THEIR APPLICATION. PRICING IS F.O.B.**



**ELECTRO-FLEX HEAT**  
a Division of ThreeHeat, LLC

5 Northwood Rd  
Bloomfield, CT 06002  
Phone: 860-242-6287  
Fax: 860-242-7298  
[www.electroflexheat.com](http://www.electroflexheat.com)

EFH1005 Issue 4  
September 2011  
©2011 Electro-Flex Heat, a Division of ThreeHeat LLC

