



# ELECTRO-FLEX HEAT

a Division of ThreeHeat, LLC

## Product Data Sheet for Motor Heaters

### FEATURES

- Standard sizes in the most frequently requested dimensions for immediate delivery
- 120V and 240V standard
- Operating temperature range of -70°F to 400°F
- Resistant to many chemical substances
- UL Recognized and CSA Certified
- Custom products available

### APPLICATIONS

Provide condensation build-up protection and freeze prevention in electric motors:

- Shipboard and marine equipment such as pumps
- Dockside equipment such as cranes and elevators

Please contact the engineering department at Electro-Flex Heat, a Division of ThreeHeat, LLC, for assistance with specific applications.

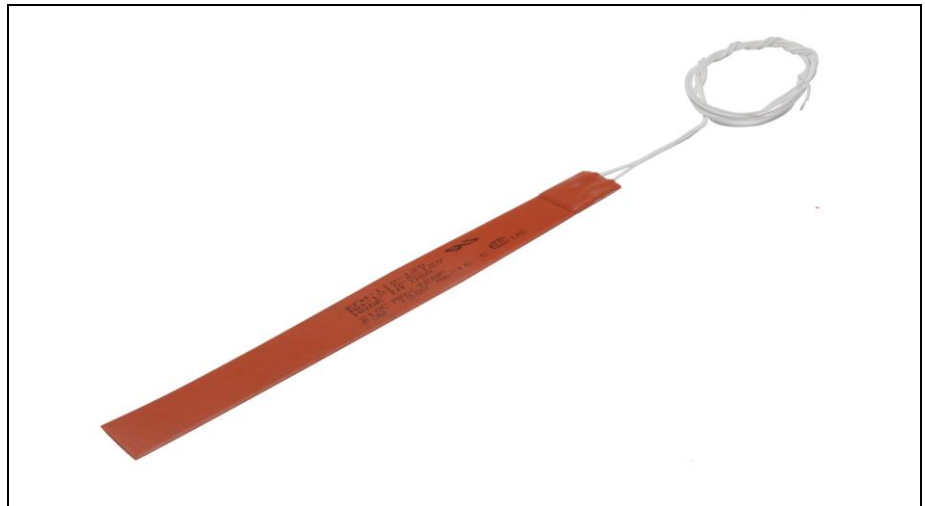

### GENERAL INFORMATION

Motor Heaters have wire-wound or etched foil heating circuits laminated between thin layers of fiberglass-reinforced, high temperature insulation, silicone rubber.

Motor Heaters help prevent moisture build-up in electrical motors by warming the motor's electrical windings. Condensation occurs when humid air comes in contact with the cool metal of the motor, which, if allowed to collect over a period of time, will corrode the windings, degrading motor performance and contributing to premature motor failure. Condensation prevention is especially critical for equipment operating in tropical environments where continuous humidity can quickly degrade an electric motor. Motor Heaters also provide warm start-ups, which helps extend motor life. To install, simply wrap the heater around the inside motor housing.

These heaters are not equipped with a temperature controller. If a Motor Heater is being used in a temperature-sensitive environment, a thermal device, such as a thermostat, should be used to ensure temperature control. They also do not have a grounding plane and must be grounded to prevent electrical build-up.

### How to order:

1. Determine specifications desired (see Figure 1 and Table 2).
2. Specify model number (see Figure 2).
3. Contact factory or representative (see back page for contact information)



**Table 1. General Specifications**

Characteristic	Value
Material and construction	fully vulcanized fiberglass-reinforced silicone rubber encapsulating a nickel alloy or thin foil heating element
Voltage	120V, 240V
Power density (120V, 240V))	5W/in. <sup>2</sup>
Operating temperature range	-70°F to 400°F
Exposure temperature range	-70°F to 400°F
Temperature rise potential	up to 345°F
Resistance tolerance	±10%
Thickness	0.045in. to 0.070in. (except at lead exit)
Leads: gage insulation length	22 AWG Teflon® 24.0in. min.
Component approvals	UL, CSA
High-potential dielectric testing (115V)	1250V
Serviceable parts	none

**Figure 1. Dimensions (For reference only. in.)**

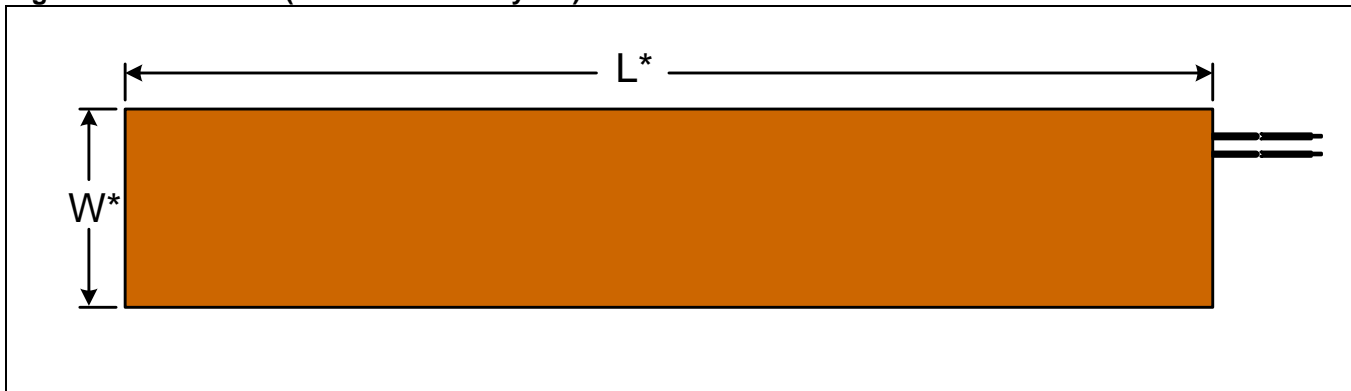

\*See Figure 2 for available widths and lengths.

# Motor Heaters



**Table 2. Electrical Properties**

Width (in.)	Length (in.)	Wattage (W)	Current Draw (A)	
			120V	240V
1.0	5.0	25	0.25	0.1
1.0	10.0	50	0.42	0.21
1.0	15.0	75	0.63	0.31
1.0	20.0	100	0.83	0.42
1.0	25.0	125	1.04	0.52
2.0	15.0	150	1.25	0.63
2.0	20.0	200	1.67	0.84
2.0	25.0	250	2.08	1.04

**Figure 2. Model Number Order Guide**

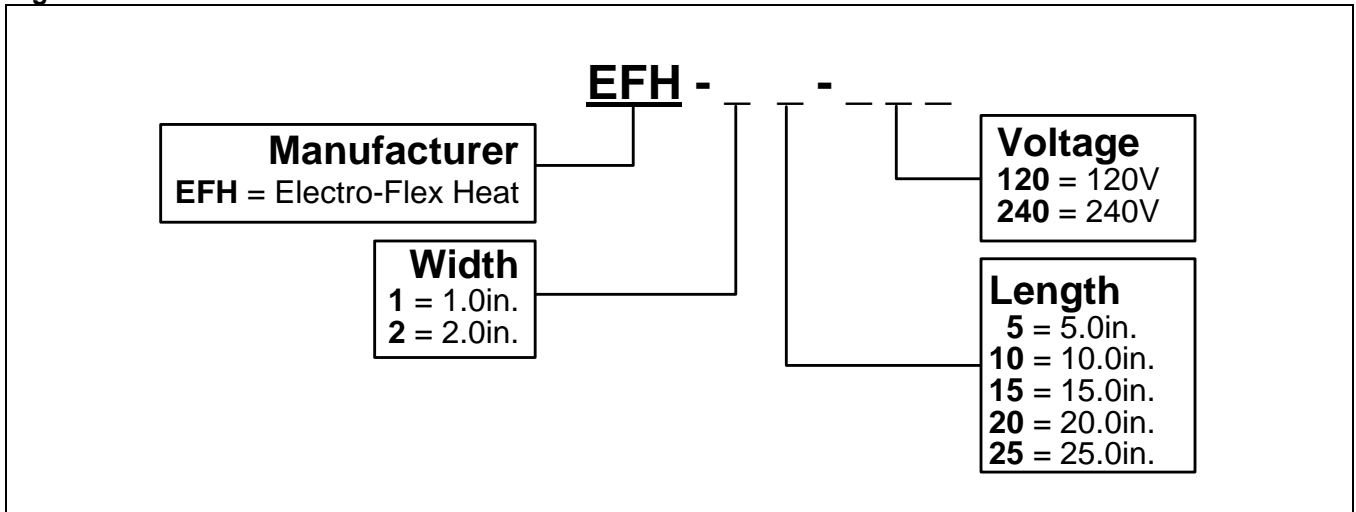



## WARRANTY AND LIMITATION OF REMEDY AND LIABILITY

**Electro-Flex Heat, a Division of ThreeHeat, LCC (hereafter referred to as “Electro-Flex Heat”)** warrants its products against defects in material and workmanship for at least one (1) year from the time of delivery, provided such product is properly applied, used and maintained. **Electro-Flex Heat** does not warrant any product against damage from corrosion, contamination, misapplication, improper specification or wear and tear and operational conditions beyond **Electro-Flex Heat’s** control. The terms of this warranty are the exclusive terms available to buyer and to any other person or entity to which products are transferred during the period of this warranty. No person has authority to bind **Electro-Flex Heat** to a presentation or warranty other than this express warranty.

**Electro-Flex Heat** shall not be liable for incidental or consequential damages resulting from use of the products whether a claim for such damage is based upon warranty, contract, negligence or other cause of action. Should any product fail while subject to this warranty, such product shall be repaired or replaced, at **Electro-Flex Heat’s** option, at no charge to buyer or to any other person or entity to which product is transferred during the period of this warranty. **Electro-Flex Heat** must be notified of the alleged failure of the product within thirty (30) days of such event and advanced authorization for repair or replacement must be obtained in writing from **Electro-Flex Heat**.

**THIS WARRANTY IS MADE EXPRESSLY IN LIEU OF ALL OTHER WARRANTIES, EXPRESS OR IMPLIED, INCLUDING WITHOUT LIMITATION, ANY WARRANTY ARISING FROM A COURSE OF DEALING OR USAGE OF TRADE, AND ALL OTHER SUCH WARRANTIES ARE SPECIFICALLY EXCLUDED. THE CORRECTION OF ANY DEFECT IN OR FAILURE OF PRODUCTS BY REPAIR OR REPLACEMENT TO THE EXTENT SET FORTH ABOVE, SHALL BE Electro-Flex Heat’s LIMIT OF LIABILITY AND THE EXCLUSIVE REMEDY FOR ANY AND ALL LOSSES, DELAYS OR DAMAGES RESULTING FROM THE PURCHASE OR USE OF THE PRODUCTS. IN NO EVENT SHALL Electro-Flex Heat BE LIABLE FOR SPECIAL, INDIRECT, INCIDENTAL OR CONSEQUENTIAL DAMAGES. Electro-Flex Heat SHALL NOT BE LIABLE FOR, BUYER AND ANY OTHER PERSON OR ENTITY TO WHOM PRODUCTS ARE TRANSFERRED DURING THE PERIOD OF THIS WARRANTY ASSUMES RESPONSIBILITY FOR, ALL PERSONAL INJURY AND PROPERTY DAMAGE RESULTING FROM OR RELATED TO THE HANDLING, POSSESSION OR USE OF PRODUCTS AND PRODUCTS MANUFACTURED AND SOLD BY Electro-Flex Heat HEREUNDER.**

**Electro-Flex Heat IS NOT LIABLE FOR LABOR COST INCURRED IN REMOVAL, REINSTALLATION, OR AUTHORIZED REPAIR OF THE PRODUCT OR FOR DAMAGE OF ANY TYPE WHATSOEVER, INCLUDING INCIDENTAL OR CONSEQUENTIAL DAMAGE.**

**USERS ARE RESPONSIBLE FOR THE SUITABILITY OF THE PRODUCTS TO THEIR APPLICATION. PRICING IS F.O.B.**



5 Northwood Rd  
Bloomfield, CT 06002  
Phone: 860-242-6287  
Fax: 860-242-7298  
[www.electroflexheat.com](http://www.electroflexheat.com)

EFH1006 Issue 1  
November 2010  
©2010 Electro-Flex Heat, a Division of ThreeHeat LLC

